

Made in Holland

PITT
COOKING

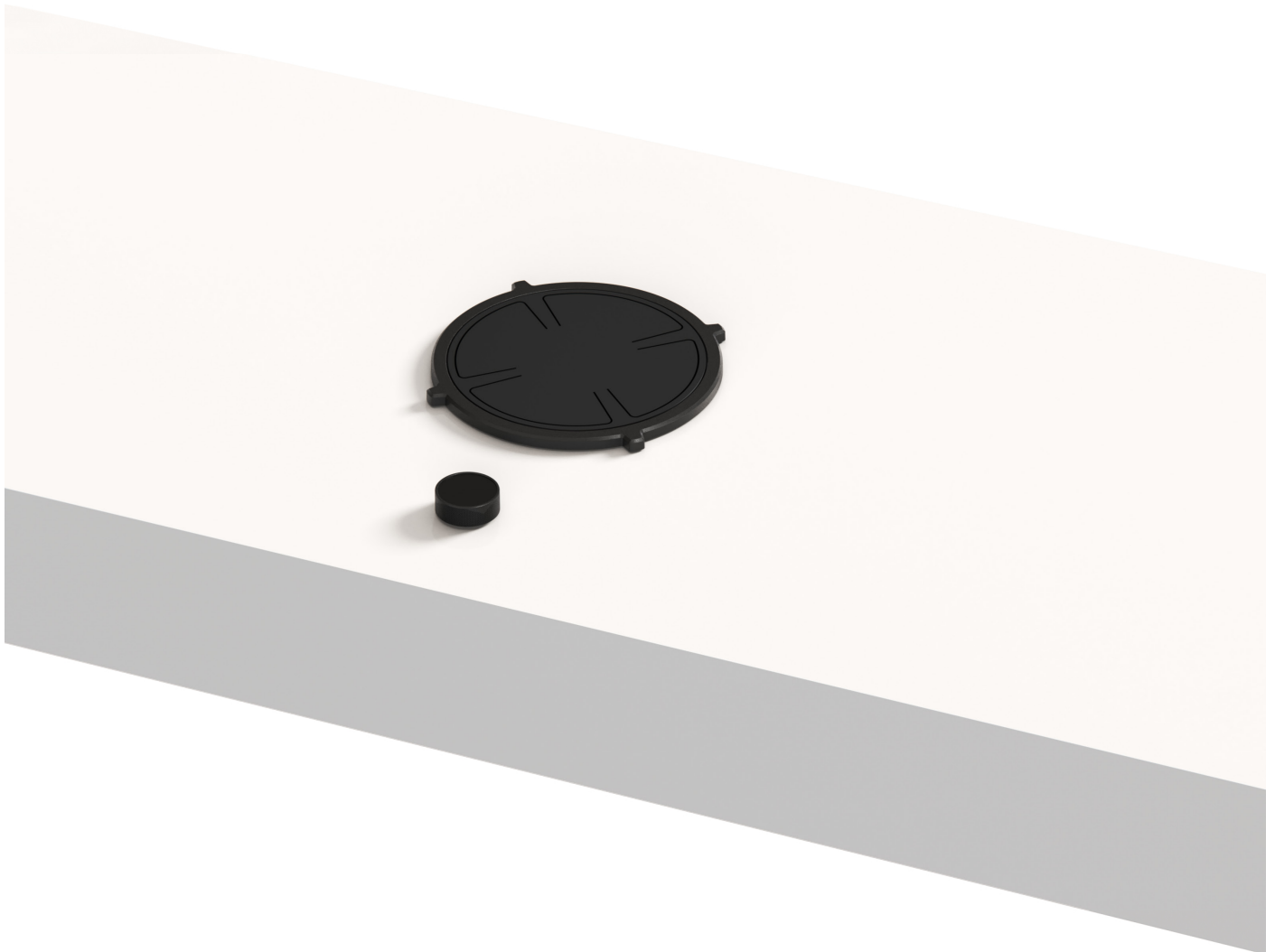

Induction

Akan-I

Top Side

Exploded view

Induction zones

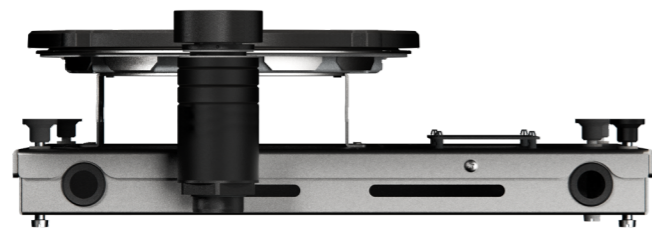

1. **Decorative ring small**
PVD COATED ALUMINUM

2. **Induction zone small**
PVD COATED ALUMINUM/ CERAMIC GLASS

3. **Control knob**
ALUMINUM/GLASS

4. **Cassette**
ALUMINUM

Small zone

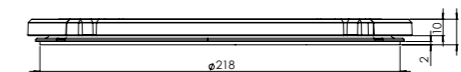
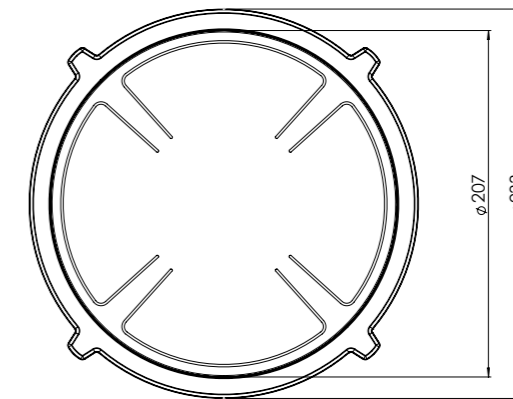

SMALL ZONE

NOM. POWER
1400 Watt
MIN. DIAM. PAN
110 mm

MAX. POWER
2100 Watt
MAX. DIAM. PAN
210 mm

Control knob

3D-visualization of Top Side knob



3D-visualization Front Side knob



Dimensions control knob

Front view

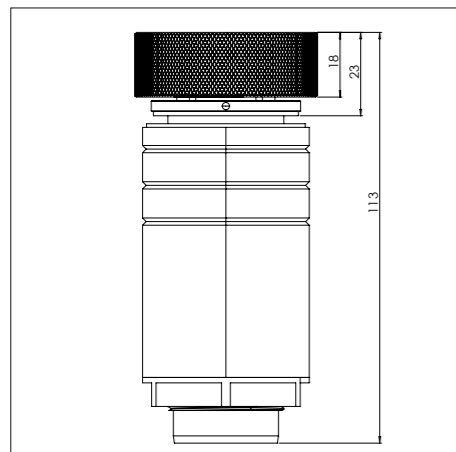

Top view

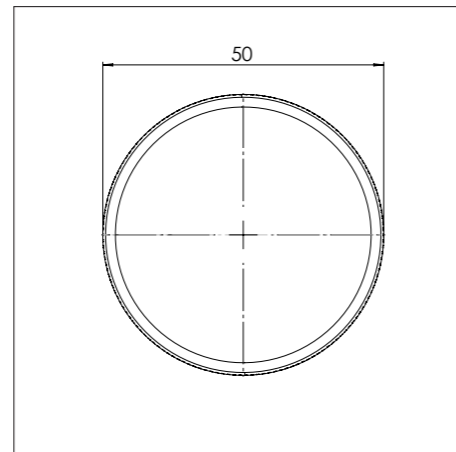

Control knob

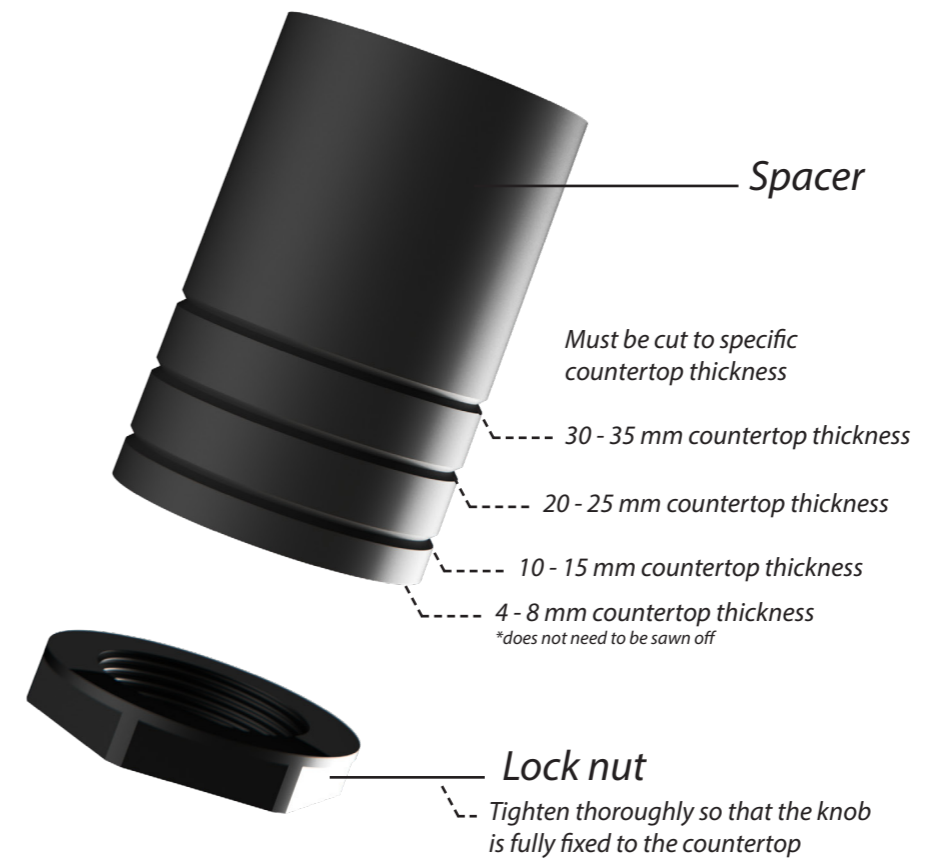
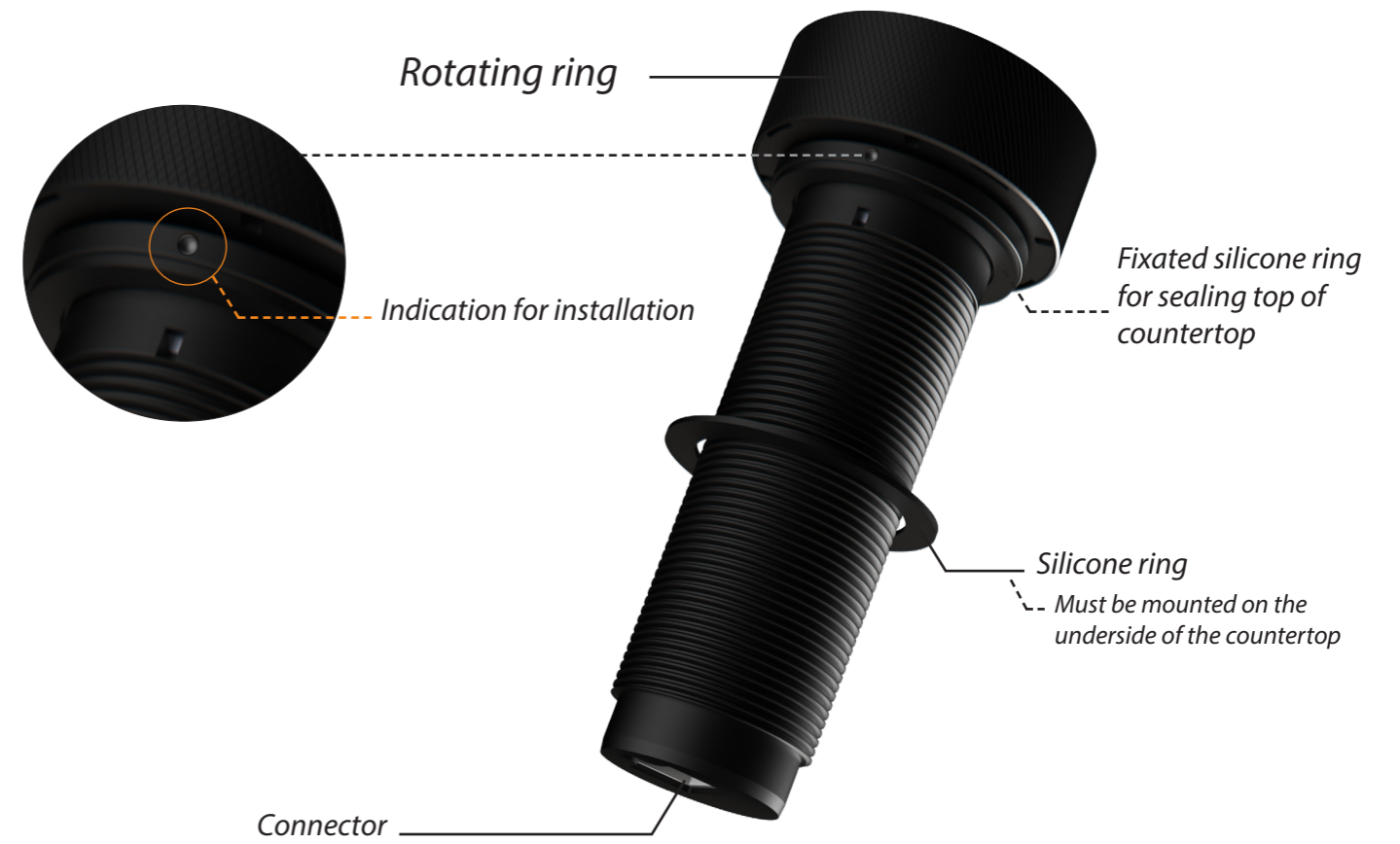

Technical drawing

Technical drawing

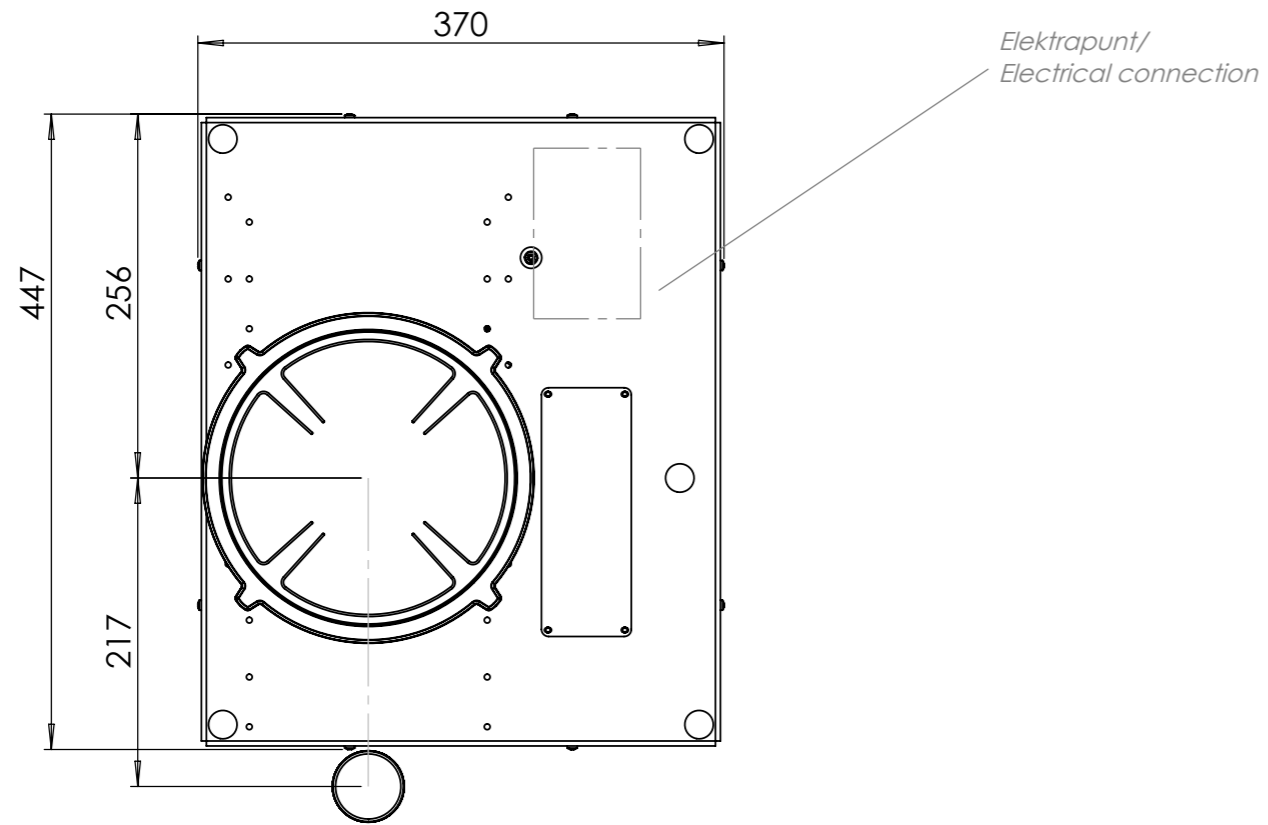

Bovenaanzicht / Top view

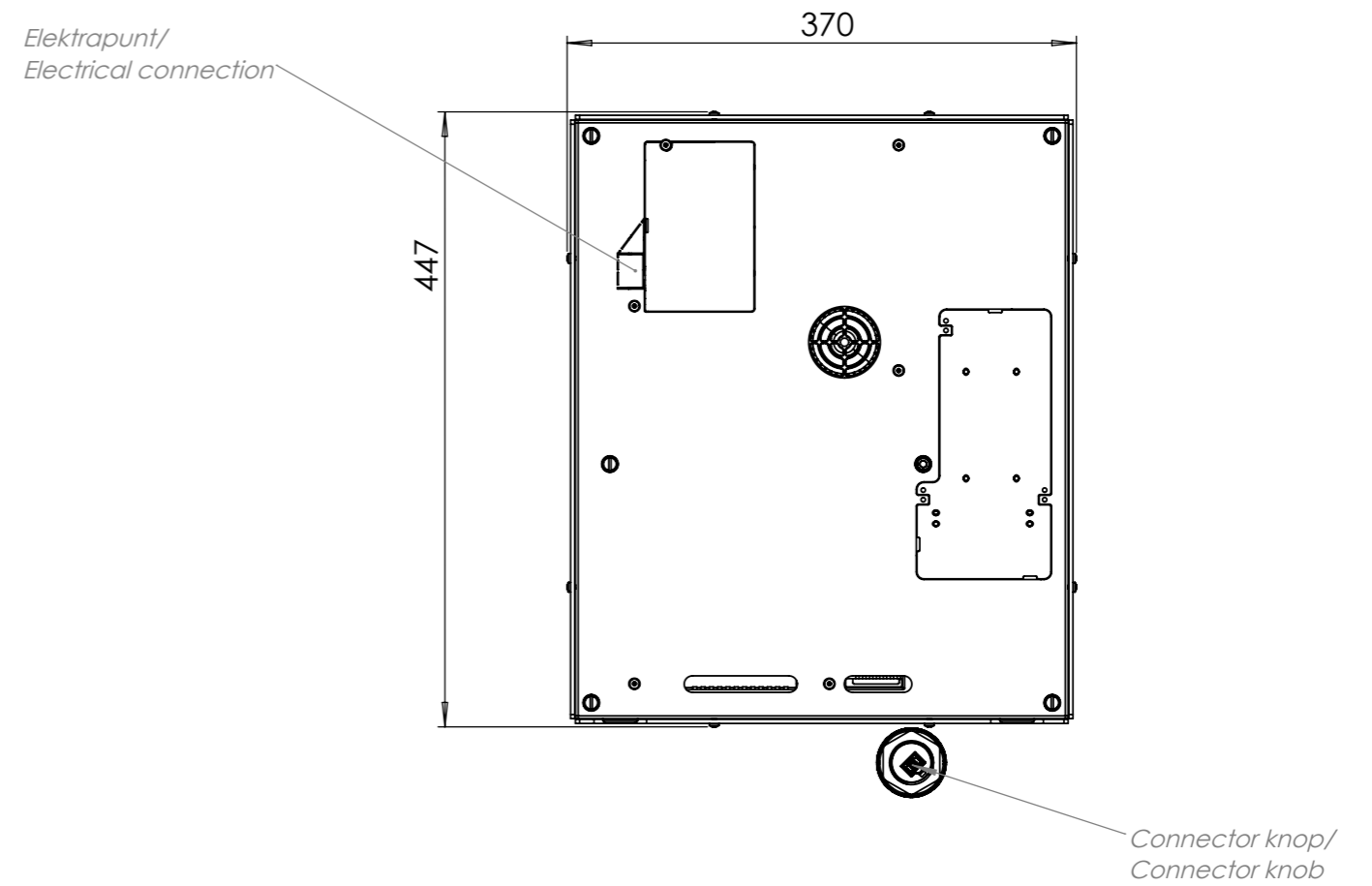

Onderaanzicht / Bottom view

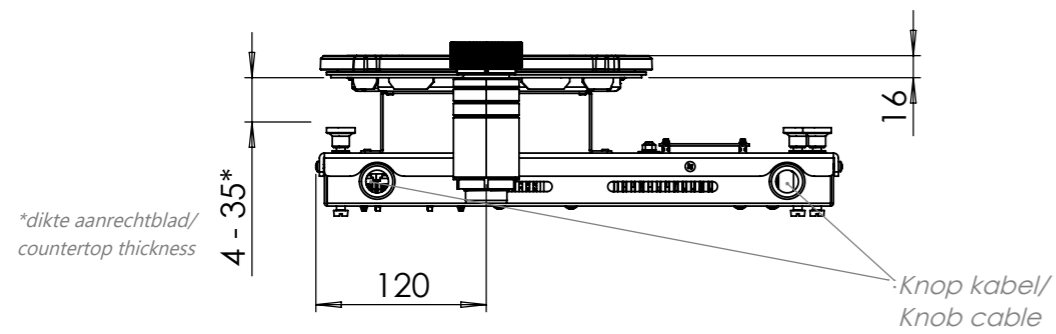

Vooraanzicht / Front view

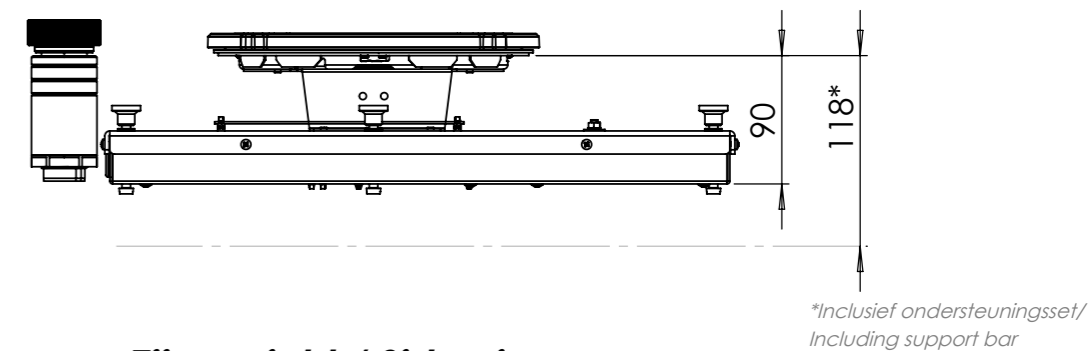

Zijaanzicht / Side view

Hole pattern

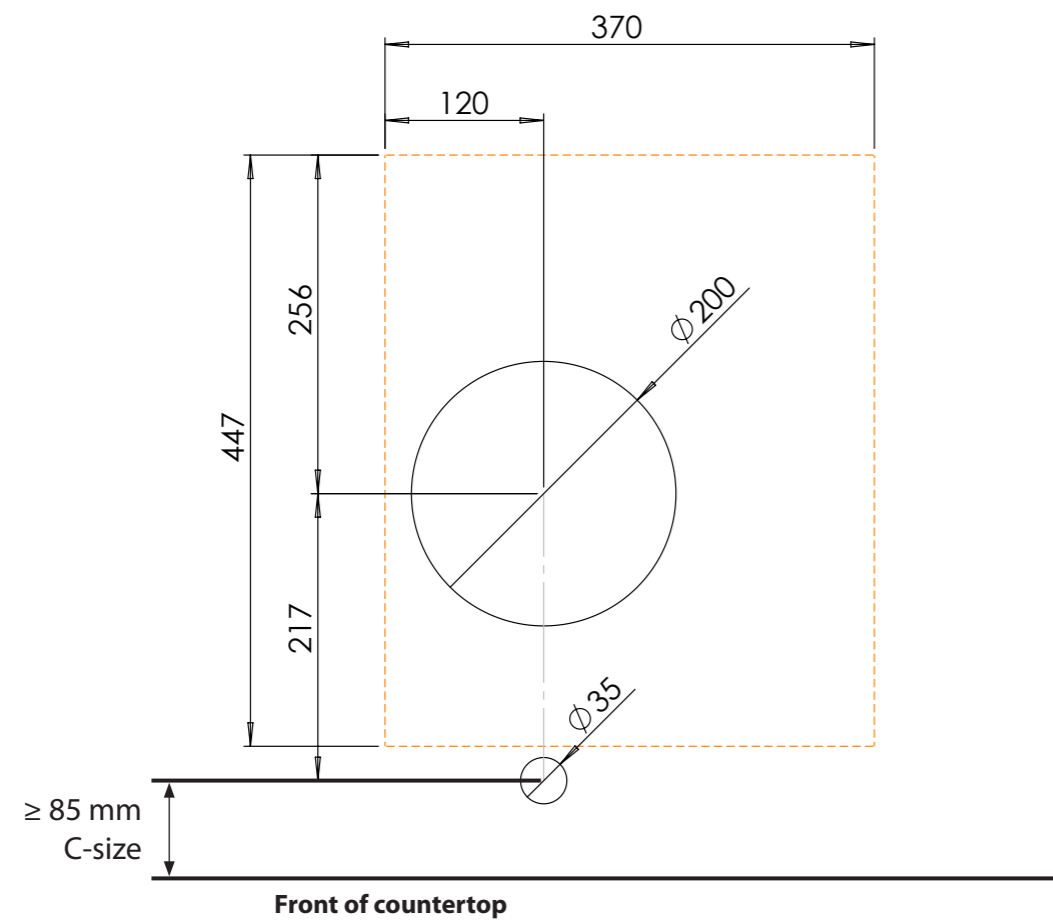

Hole pattern
DXF file

Technical information

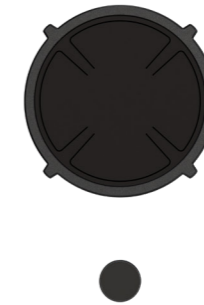

Model	Akan Top Side
Type zones	1x zone small
Editions	Black (fully black)
Automatic pan detection	✓
Power levels	0 - 10 + Boost
Nominal voltage	220-240 V, 1N~
Maximum power	2100 W
Netto weight	6 kg

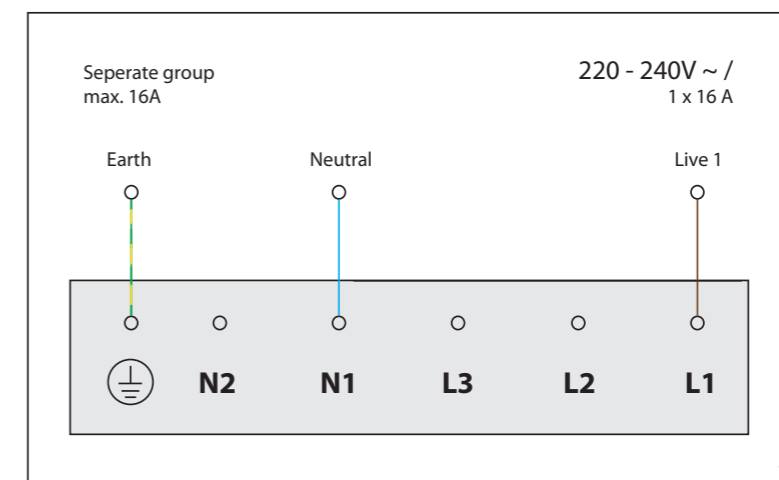

Ø ≥ 2.5mm²





Installation and handling instructions



Installation manual induction



User manual induction

Made in Holland

PITT
COOKING

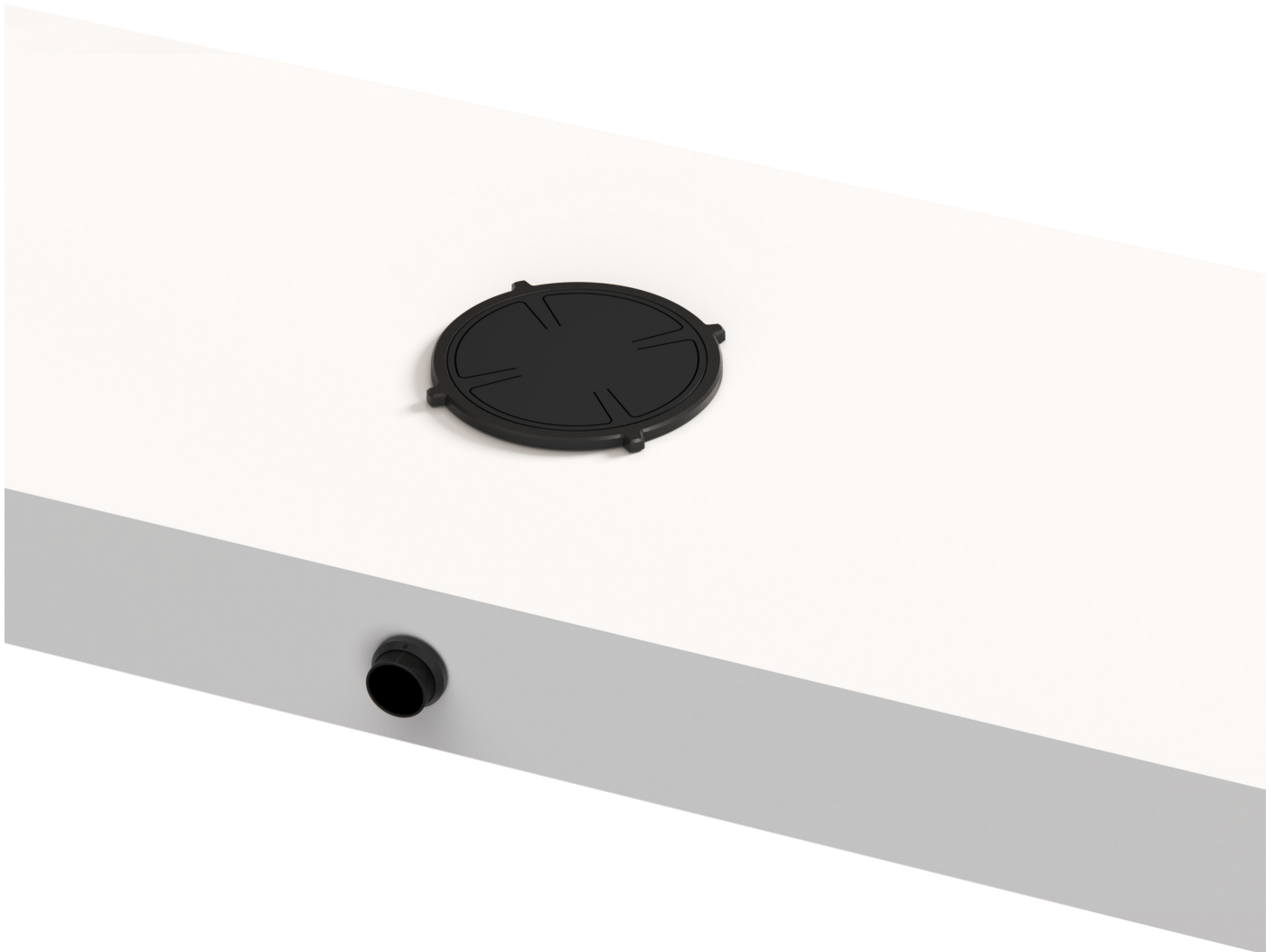

Induction

Akan-I

Front Side

Exploded view

Induction zones

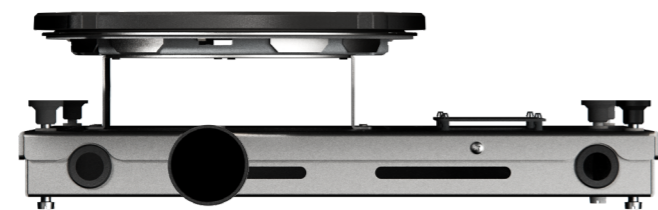

1. **Decorative ring small**
PVD COATED ALUMINUM

2. **Induction zone small**
PVD COATED ALUMINUM/ CERAMIC GLASS

3. **Control knob**
ALUMINUM/GLASS

4. **Cassette**
ALUMINUM

Small zone

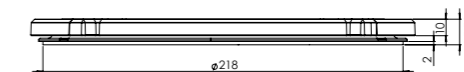
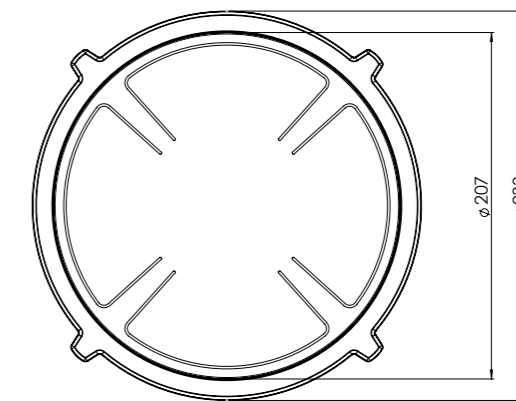

SMALL ZONE

NOM. POWER
1400 Watt
MIN. DIAM. PAN
110 mm

MAX. POWER
2100 Watt
MAX. DIAM. PAN
210 mm

Control knob

3D-visualization of Top Side knob



3D-visualization Front Side knob



Dimensions control knob

Front view

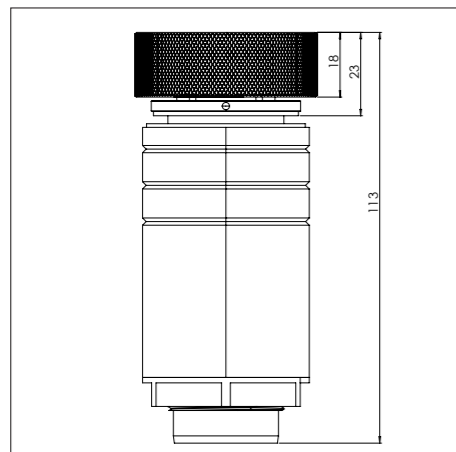

Top view

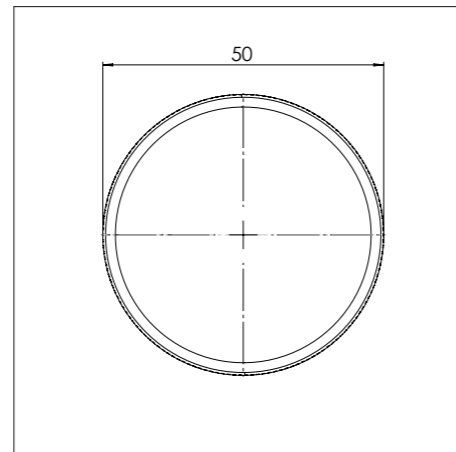

Control knob

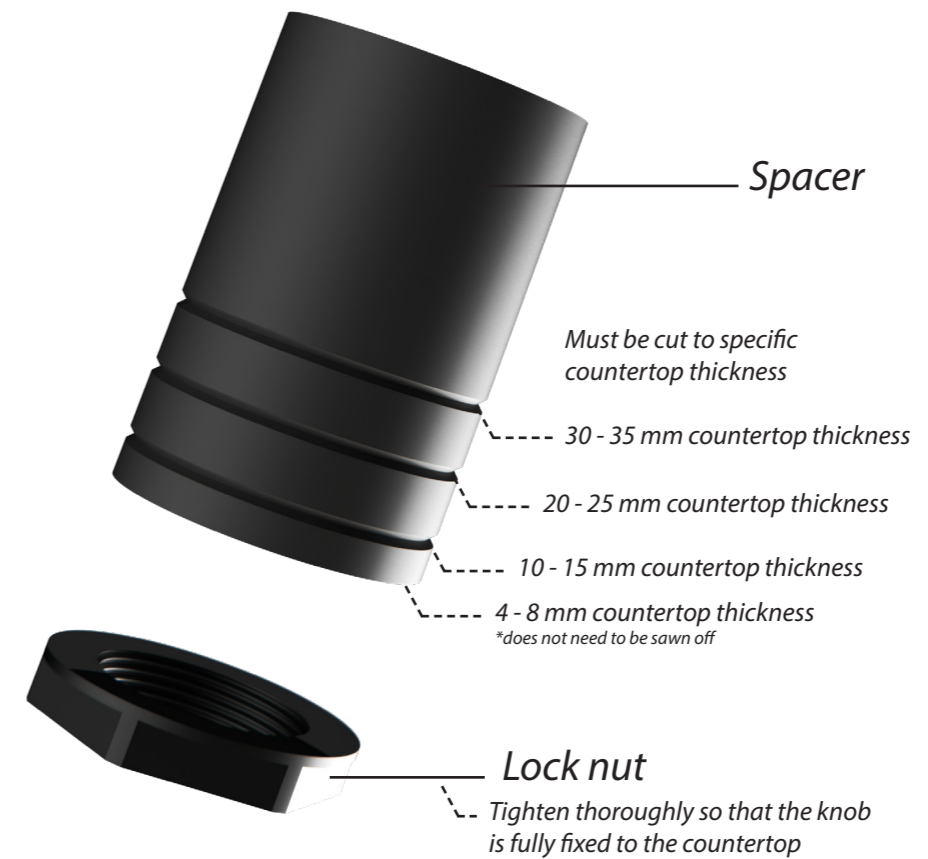
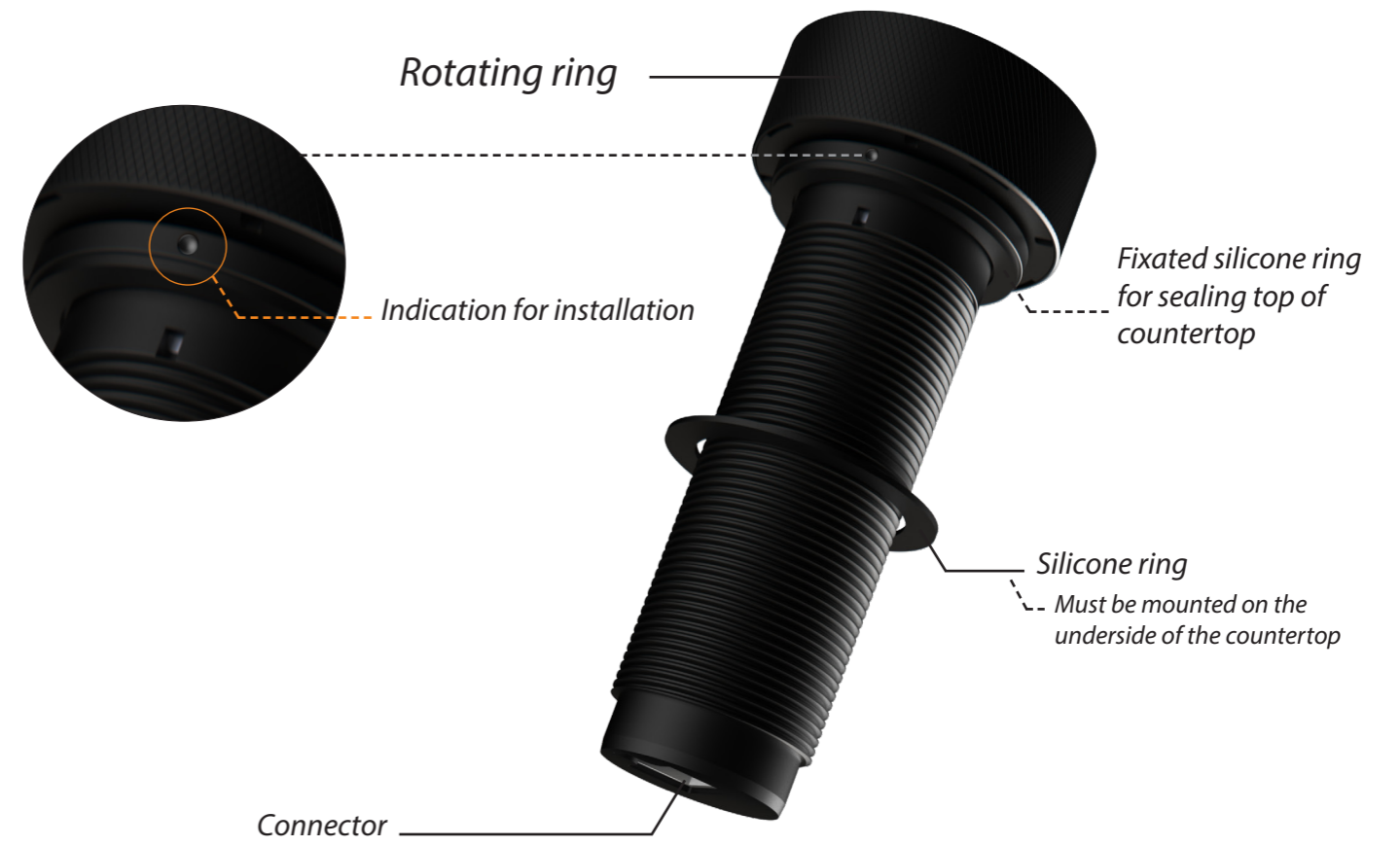

Technical drawing

Technical drawing

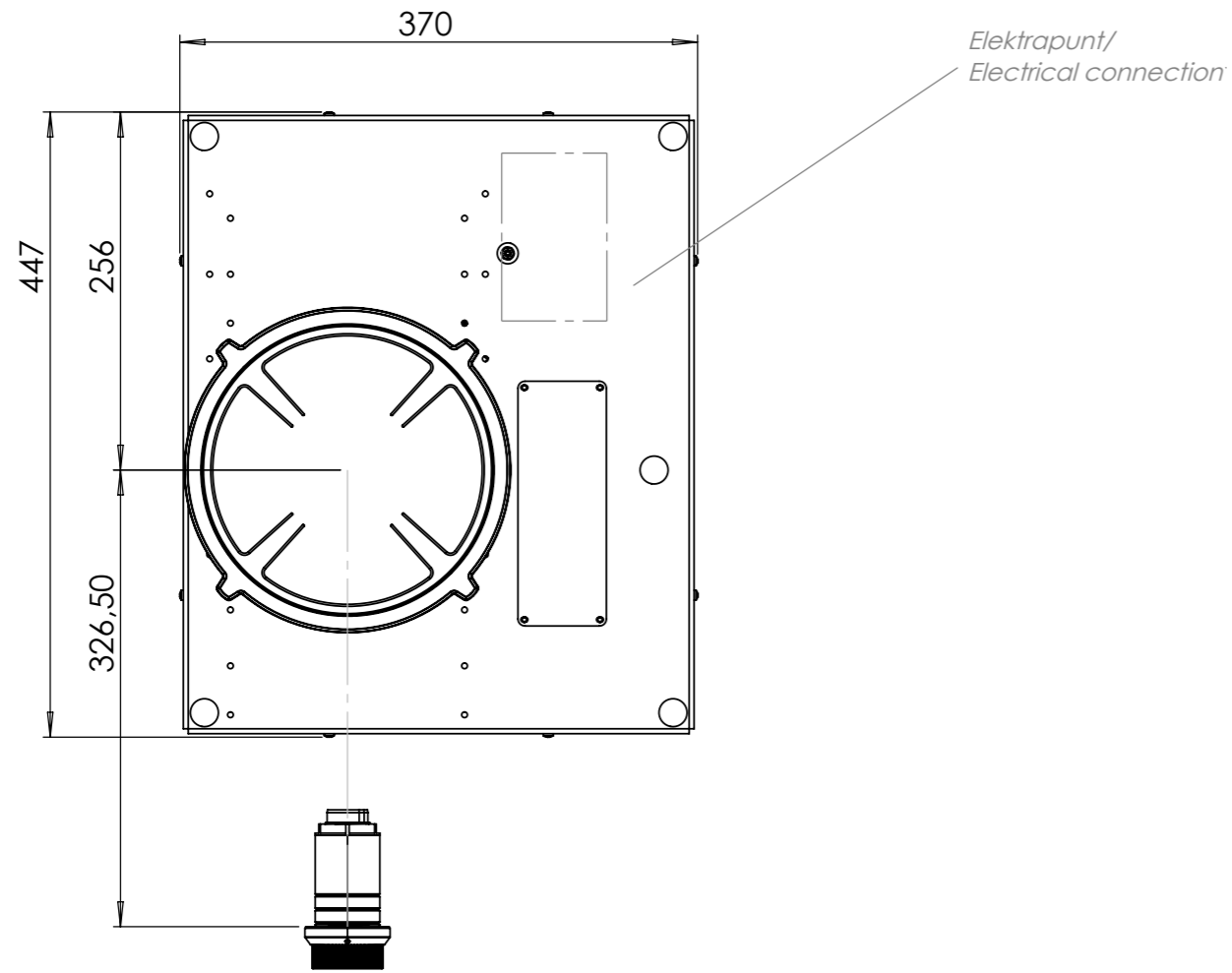

Bovenaanzicht / Top view

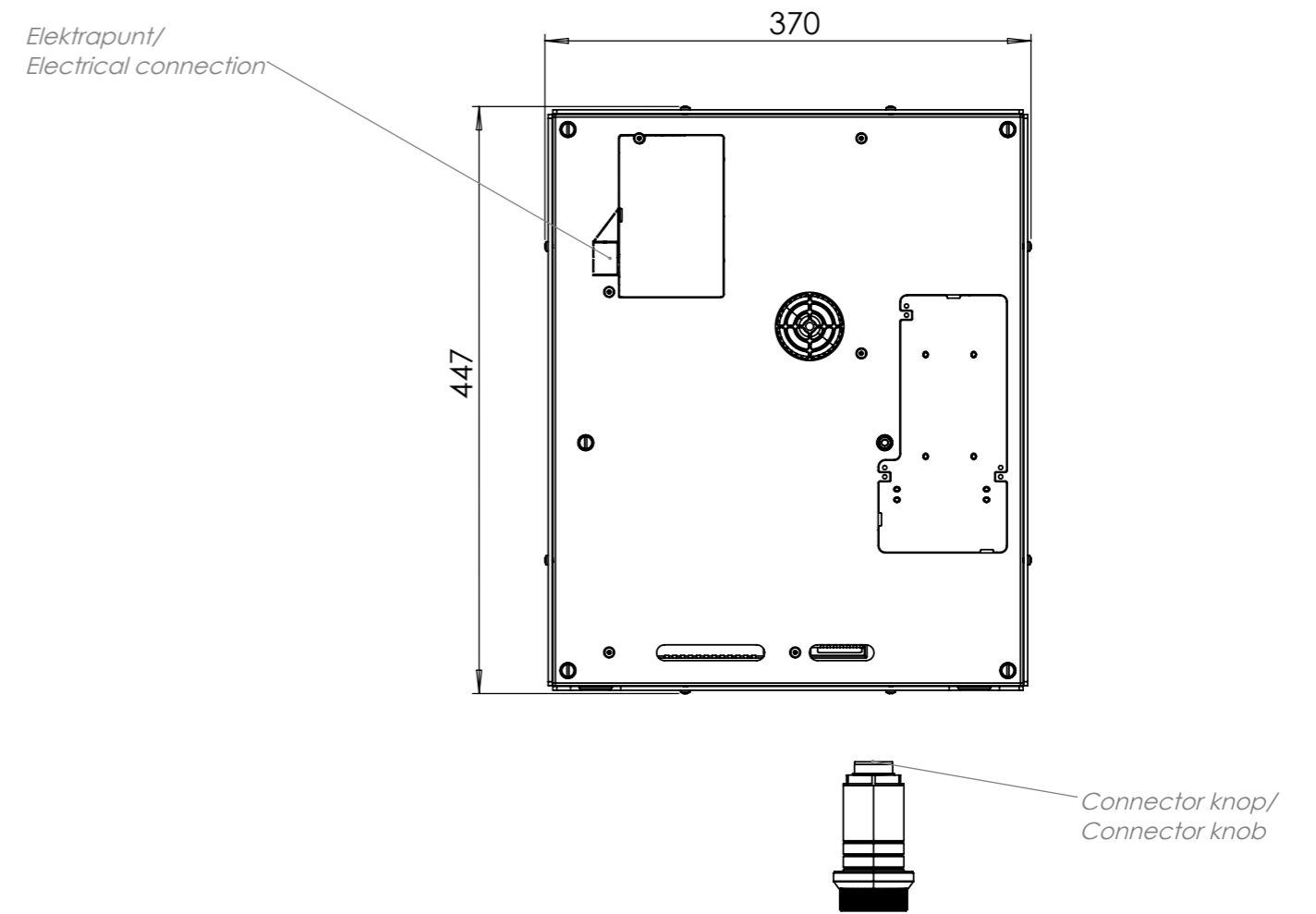

Onderaanzicht / Bottom view

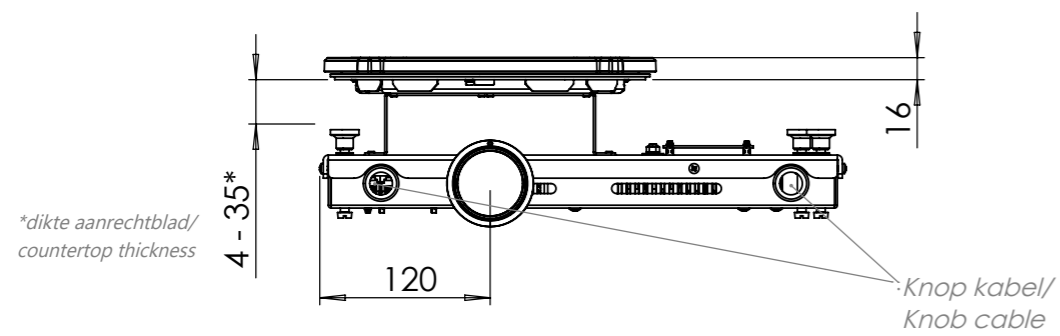

Vooraanzicht / Front view

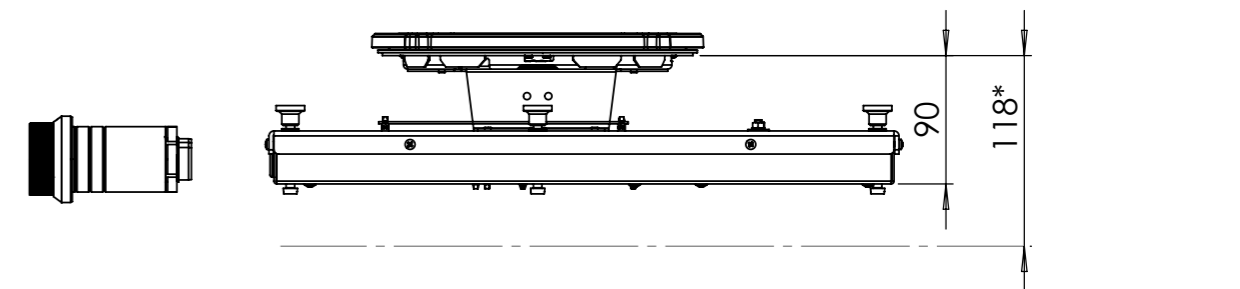

Zijaanzicht / Side view

**Inclusief ondersteuningsset/
Including support bar*

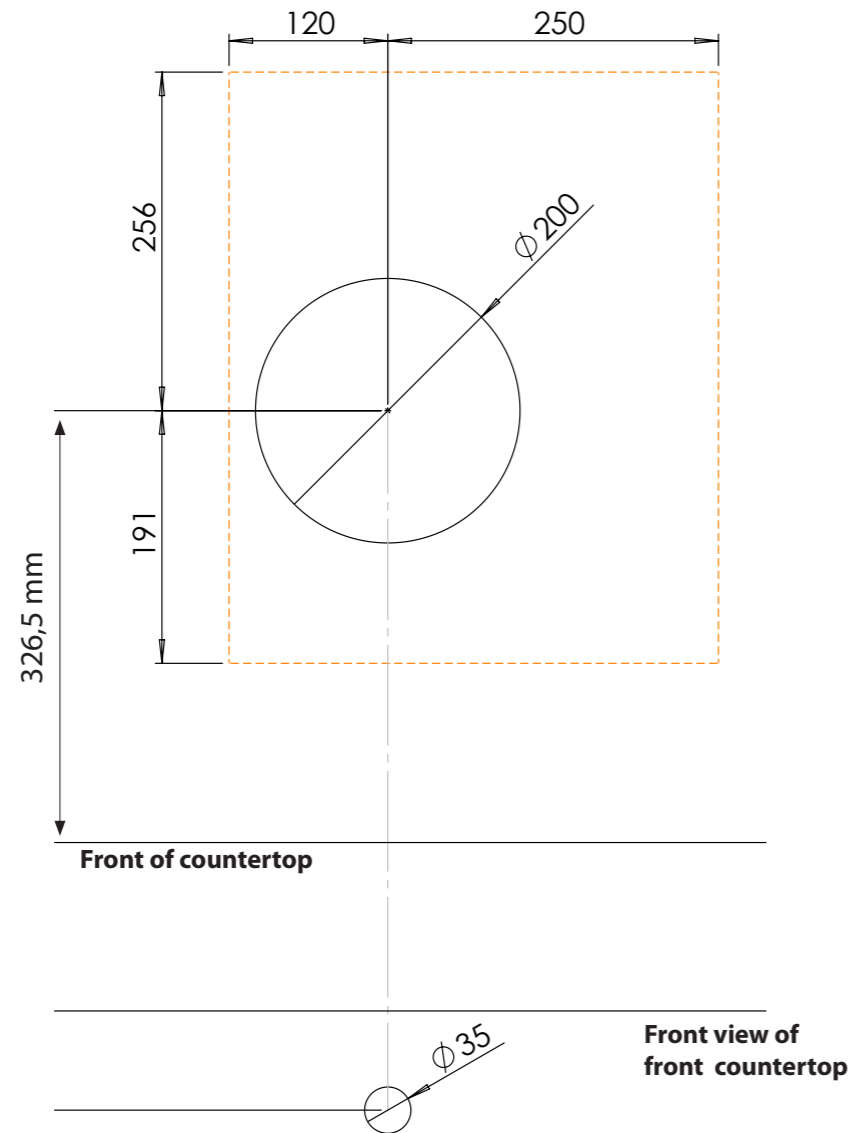

Hole pattern DXF file

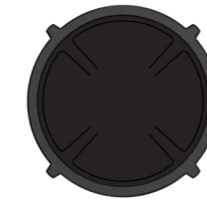

Model	Akan Front Side
Type zones	1x zone small
Editions	Black (fully black)
Automatic pan detection	✓
Power levels	0 - 10 + Boost
Nominal voltage	220-240 V, 1N~
Maximum power	2100 W
Netto weight	6 kg

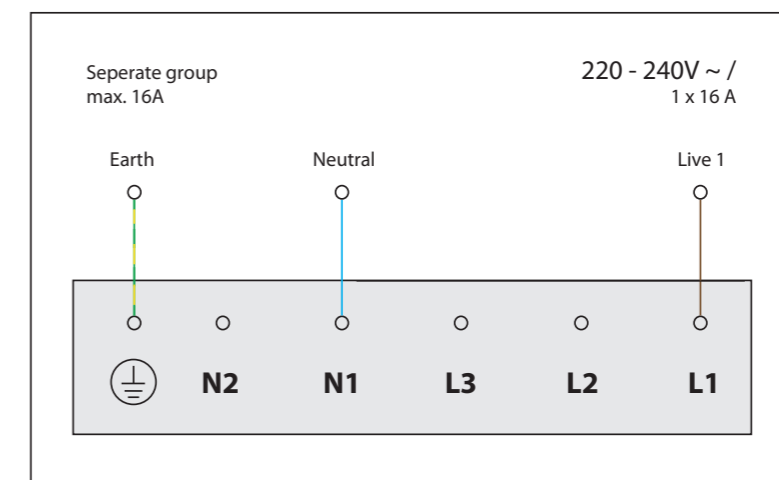



Installation and handling instructions



Installation manual induction



User manual induction